



HOME & GARDEN

# 403

INTERNAL PISTON PUMP  
OCCASIONAL USER

## Instruction Manual



P.1 .....	Index
P.2 .....	Unpacking
P.3 .....	1. Introduction 2. Specifications 3. Safety Warnings & Operation
P.4 .....	4. Assembly
P.5 .....	5. Nozzle & Performance
P.6 .....	6. Application
P.7.....	7. Parts Breakdown
P.9 .....	8. Important Return Safety Instructions 9. Statement of Limited Warranty 10. Maintenance & Lubrication
P.10 .....	11. Troubleshooting

# Unpacking

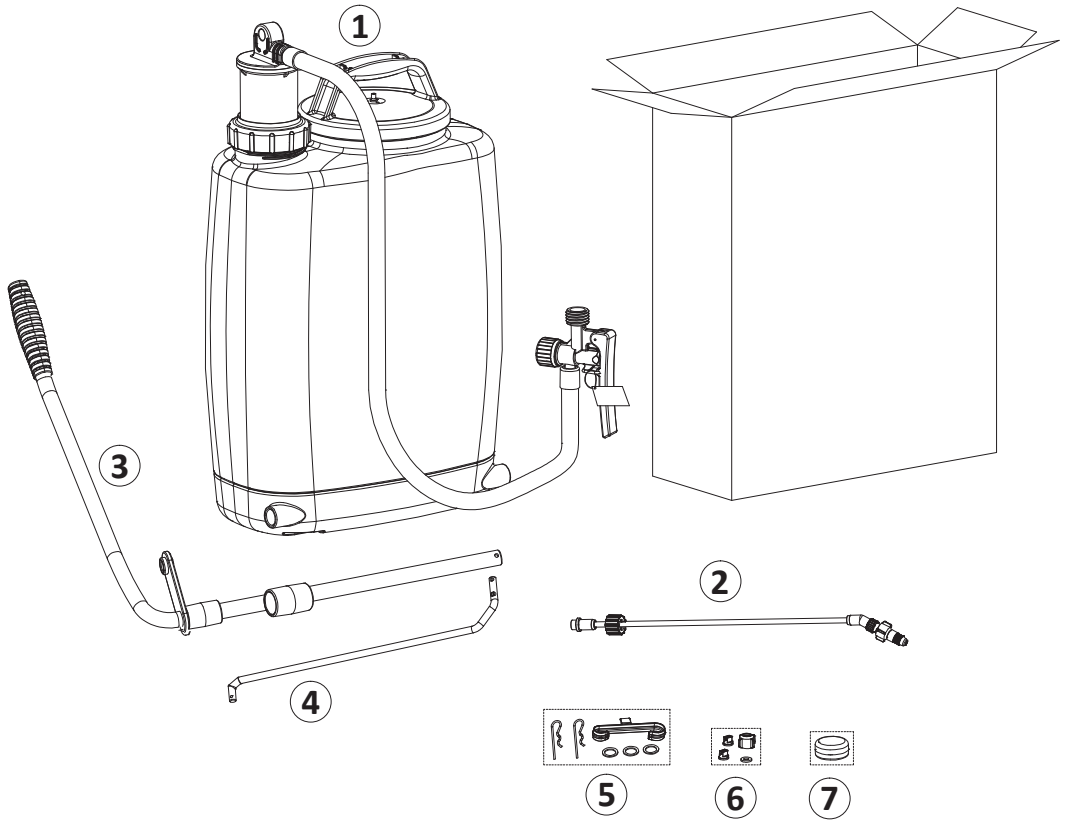

1) Sprayer

4) Pump Lever

7) Silicone Grease

2) Wand

5) Lever Holder & Locking Pin

3) Pump Handle

6) Nozzles

# 1. Introduction

This manual contains information for the proper assembly, operation and care of your sprayer. Carefully read and follow the instructions contained in this manual before using your sprayer.

## 2. Specifications

<b>Target Market</b>	Home & Garden
<b>Pump Type</b>	Piston Pump
<b>Capacity US Gallons (Ltr)</b>	4 (15)
<b>Dry Weight lbs. (kg)</b>	9.4(4.2)
<b>Seals &amp; O-Rings</b>	High Grade Proprietary Material
<b>Spray Gun</b>	Spray-Plus™ with lock pin
<b>Wand</b>	20" Fiberglass
<b>Hose</b>	51" Reinforced PVC
<b>Frame Material</b>	Tubular Steel
<b>Max PSI</b>	60
<b>Working PSI</b>	15-50
<b>Standard Nozzle</b>	- Plastic Adjustable
<b>Fan Nozzle</b>	- Plastic 90° / 110°
<b>Shoulder Strap</b>	Polypropylene / Adjustable Strap
<b>Mouth Opening inch</b>	5.24" QuickFill
<b>Warranty</b>	1 Year (Commercial & Residential)

## SAFETY GUIDELINES - DEFINITIONS

This is important to read and understand this manual and the information relates in protecting YOUR SAFETY and PREVENTING PROBLEM. The symbols below are used to help recognizing the information.



### DANGER!

Indicates an imminently hazardous situation which, if not avoided will result in death or serious injury.



### WARNING!

Indicates a potentially hazardous situation which, if not avoided, could result in death or serious injury.



### CAUTION

Indicates a potentially hazardous situation which, if not avoided, may result in minor or moderate injury.

# 3. Safety Warnings & Operation

## WARNING:

- (1) Read this Sprayer Owner/Operator Manual carefully. Be sure you understand how to operate this unit properly before you use it. Failure to do so could result in serious injury.
- (2) Be sure to keep this manual handy so that you may refer to it later whenever any questions arise. Also note that you are requested to contact the dealer from whom you purchased the product for assistance in the event that you have any questions which cannot be answered herein.
- (3) Always be sure to include this manual when selling, lending, or otherwise transferring the ownership of this product.
- (4) Do not lend or rent your machine without the owner's manual.
- (5) Be sure that anyone using your unit understands the information contained in this manual.
- (6) Never let a child under 13 years old uses the machine.
- (7) DO NOT use flammable in the sprayer. They can ignite or explode causing serious injury.
- (8) Always wear splash goggle and protective gears and clothing when filling, using and/or cleaning the sprayer.
- (9) Lubricate the rubber lid o-ring with Silicone Grease prior to first usage to ensure it will seal properly.
- (10) Tighten all connections before using the sprayer. For some may not be properly secured must be tightened to prevent leakage.

## BEFORE USING:

- Lubricate all moveable rubber pieces with Silicone Grease (o-rings, seals, piston cup (if applicable), spindle in gun).
  - Keep breather hole in lid clear of debris.
  - Lubricating the seals and keeping the breather hole opens to allow air flow into the tank. Without a proper breather hole opens, the tank may collapse and crack due to the air vacuum from pumping
- ### 3.1 WORKING CONDITION
- Refrain from operating the sprayer if you are tired, ill, or upset, or if you are under the influence of alcohol, drugs or medication.
- To reduce the risk of injury when filling, using and/or cleaning the sprayer, always wear eye protection. Eye protection should meet the requirements of ANSI Z87.1.
  - Always wear a mask or respirator when filling, using and cleaning sprayer, if recommended by the spray material manufacturer.
  - Wear protective gear and clothing when filling, using and cleaning the sprayer.
  - Wear sturdy rubber-soled shoes or shoes with some other form of anti-slip protection to help protect you against falling when filling, using and/or cleaning the sprayer.
  - Do not wear loose clothing, scarves, neck chains, hair longer than shoulder length when filling, using and/or cleaning the sprayer.

• Always inspect your sprayer thoroughly before and after each use. Check to be sure hose is securely attached and in good condition before pressurizing the tank.

• Check the work area that the sprayer will be used in and remove or cover all valuables that may be damaged by using sprayer.

• To reduce the risk of injury:

- Watch out for children, pets, open windows, freshly washed cars, and spray safely away.

- Do not allow bystanders in work area.

- Do not point the sprayer nozzle in the direction of people or pets.

- Pay attention to the direction of the wind, do not work against the wind.

- Never use the sprayer during windy conditions.

- Never point a sprayer nozzle toward an open flame to avoid the possibility of igniting the unit, causing injury to yourself or damage to surroundings.

- Always release pressure in the pump prior to filling, cleaning, or servicing the sprayer.

- Before opening a container of pesticide or other spray material, carefully read, understand, and follow all instructions on the label.

- Do not use flammable materials in the sprayer: They can ignite and/or explode, causing serious injury.

- Never use chlorine/bleach, caustic or corrosive materials in the sprayer, which could result in damage to the unit.

- In case of personal contamination: remove contaminated clothing, remain upright, do not consume liquids or cause vomiting, and get professional help immediately.

- Never attempt to pressurize the unit by any other method than with the pump module provided.

- Never over-pressurize the unit.

- Do not eat, drink, or smoke while spraying.

- Wash face and hands with soap and water after spraying.

- Clean and rinse tank and spraying assembly after each use to prevent crystallizing, which would later cause clogging and chemical damage to the unit.

- Do not store sprayer under pressure, or with spray solution in tank.

- Do not transfer spray materials to other containers that are used for food and/or drink containers.

- Keep spray materials locked up and out of reach of children and animals.

- Use only original manufacturer's replacement parts.

- As a rule, mix your chemicals in a separate container from which to fill the sprayer. Do not mix formulas inside the sprayer. Where an exception is made (e.g. with liquid fertilizers), fill sprayer with water BEFORE adding the active ingredient.

- Always sift formula through the screen. If there is no built-in strainer, use a screened funnel.

- Never fill the sprayer with hot liquids. Max. 30°C, or 85°F.

- Never use gasoline or other flammable materials.

- Before cleaning or servicing the sprayer, allow all pressure to escape. Do not store or transport sprayer under pressure.

- After each use, wash the sprayer, including hose, wand, and shut-off valve with plenty of fresh water. Unless spraying is to be continued within hours, drain chemical formula and thoroughly rinse the tank and all liquid ducts.

- Never store chemicals in your sprayer for any length of time.

- Do not leave the sprayer in reach of children or persons not qualified to handle it in proper fashion.

- When not in use, and especially during prolonged storage, keep your sprayer in a protected place away from direct sunlight.

- Make sure the spray hose loops freely without kinking or squeezing.

• After using sprayers and other equipment, **CLEAN UP!** Dispose of debris in trash receptacles.

## 3.2 MAINTENANCE

(1) In order to maintain your product in proper working order, perform the maintenance and checking operations described in the manual at regular intervals.

(2) Examine the sprayer at intervals for loose fasteners and rusted or damaged parts. Use special care for chemical leakage.

(3) Clean and rinse tank and spraying assembly after each use to prevent crystallizing, which would later cause clogging and chemical damage to the unit.

(4) When replacing parts and accessories, lubricate first, and always be sure to use only certified products.

(5) In the event that any part must be replaced or any maintenance or repair work not described in this manual must be performed, please contact a SP authorized servicing dealer for assistance.

(6) Do not use any accessory or attachment other than those bearing the SP mark and recommended for the unit.

(7) Under no circumstances should you ever take apart the product or alter it in any way. Doing so might result in the product becoming damaged during operation or the product becoming unable to operate properly.

(8) Units are not storage tanks and should be washed and cleaned after each use. Failure to maintain the unit damages o-rings and seals and may void the manufacturer's warranty.

## 3.3 TRANSPORTATION

• Clean and rinse tank and spraying assembly after each use to prevent crystallizing, which would later cause clogging and chemical damage to the unit.

• Drain the content from the tank before transporting or storing the sprayer.

• Secure the unit carefully to prevent movement when it is transported.

• A unit that receives a strong shock during transport and unloading may malfunction.

## 3.4 STORAGE

• Clean and rinse tank and spraying assembly after each use to prevent crystallizing, which would later cause clogging and chemical damage to the unit.

• Do not store sprayer under pressure, or with spray solution in tank.

• When storing the sprayer, choose a space indoors free from moisture and out of the reach of children.



### WARNING:

Never store chemicals in your sprayer for any length of time.

• Before you remove lid, be sure there is no pressure in the tank. To release pressure, invert unit upside down and squeeze spray pistol (aim away from you). Pressure will escape; when hissing stops, all pressure has been released.  
Remove pump assembly by turning counter-clockwise. The pump handle has two locking positions, one turning clockwise and one counter-clockwise.

• Remove lid and pour out remaining solution, then rinse all parts thoroughly with clean water.

• Add 1/2 gallon of fresh water in tank. Pressurize, and flush pumping system by depressing trigger for at least two minutes; then drain all remaining water.

• Always store tank clean and empty in a dry, shaded location.





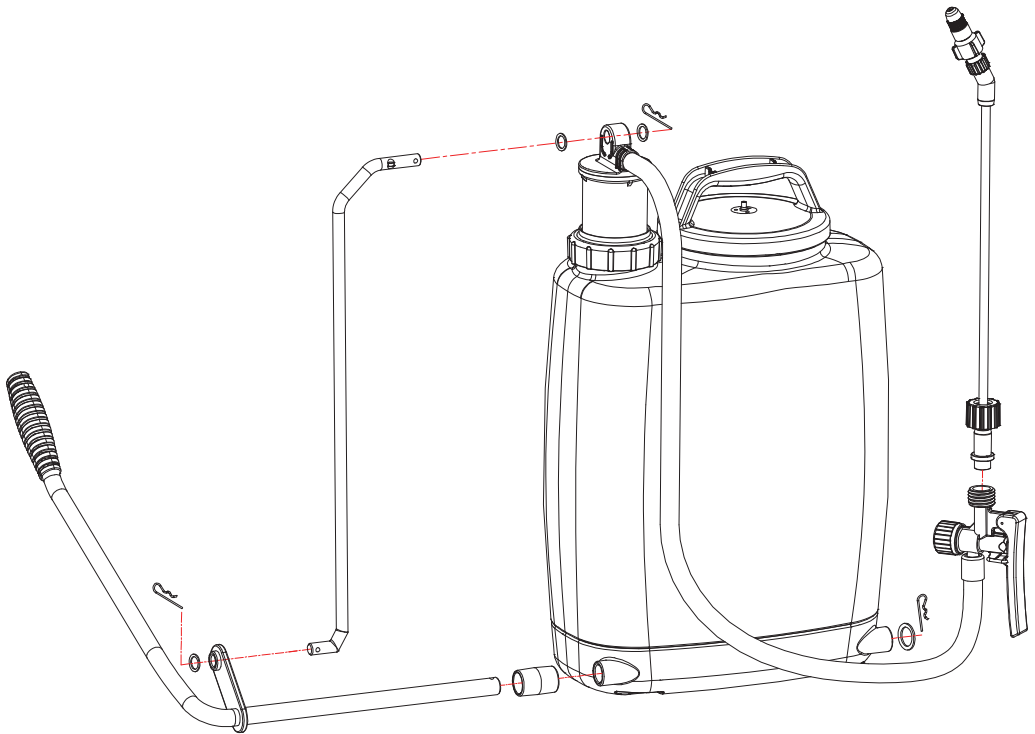

### 3.5 DISPOSAL

• When disposing of your machine, or chemical, be sure to follow your local regulations.

## 4. Assembly



## 5. Nozzle & Performance

Type	Sprayer Model	Pressure (psi/kg)	Mist setting output (ml/ min)	Steam setting output (ml/ min)	Coverage @ 3.3' height	Horizontal reach (Steam setting)
 Brass Cone (1.9mm Orifice)	100, 101, 103, 201, 202, 401, 402, YT10, YT20, YT30, 20C, 35C, PS20, 105E, 105Ex	40/2.8	1300	1950	3.6'x3.6'	33.4'
 Brass Cone (1.3mm Orifice)	YT25E	24/1.6	600	890	2.6'x2.6'	31'
 Black Cone (1.5mm Orifice)	301, 302, 403, 10ACID, 20ACID, FH10, FH20, FH30, BL20, 20ACT, 35ACT,	30/2.0	475	1000	3.2'x3.2'	36.7'
 Gray Cone (1.0mm Orifice)	BL25E, FH25E	24/1.6	370	650	2.2'x2.2'	31'
 Yellow Fan 90°	100, 101, 103, 201, 202, 301, 302, 401, 402, 403, 20C, 35C, 10ACID, 20ACID, 20ACT, 35ACT, BL20, PS20, YT10, YT20, YT30, FH10, FH20, FH30	40/2.8	1000	n/a	n/a	n/a
	BL25E, FH25E, YT25E	24/1.6	700	n/a	n/a	n/a
 Blue Fan 110°	100, 101, 103, 201, 202, 301, 302, 401, 402, 403, 20C, 35C, 10ACID, 20ACID, 20ACT, 35ACT, BL20, PS20, YT10, YT20, YT30, FH10, FH20, FH30	40/2.8	1150	n/a	n/a	n/a
	105E, 105Ex	30/2.0	1050	n/a	n/a	n/a
	BL25E, FH25E, YT25E	24/1.6	850	n/a	n/a	n/a
 Gray Fan 135°	105E, 105Ex	30/2.0	1650	n/a	n/a	n/a

## 6. Application

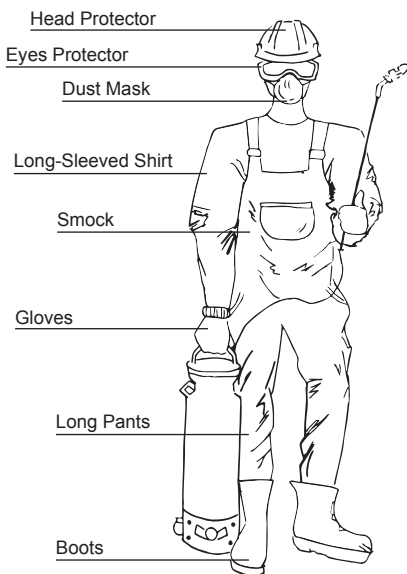

- **Protective equipments for handling chemicals is obligatory**



**WARNING:**

Use of individual protective clothing and safety equipment is required.



**WARNING:**

Use the correct dose and volume of chemical according to the product label.



**WARNING:**

Do not spray near people who are not using PPE, springs, lakes and rivers.



**WARNING:**

In case of an accident, remove the sprayer immediately.

# 7. Parts Breakdown

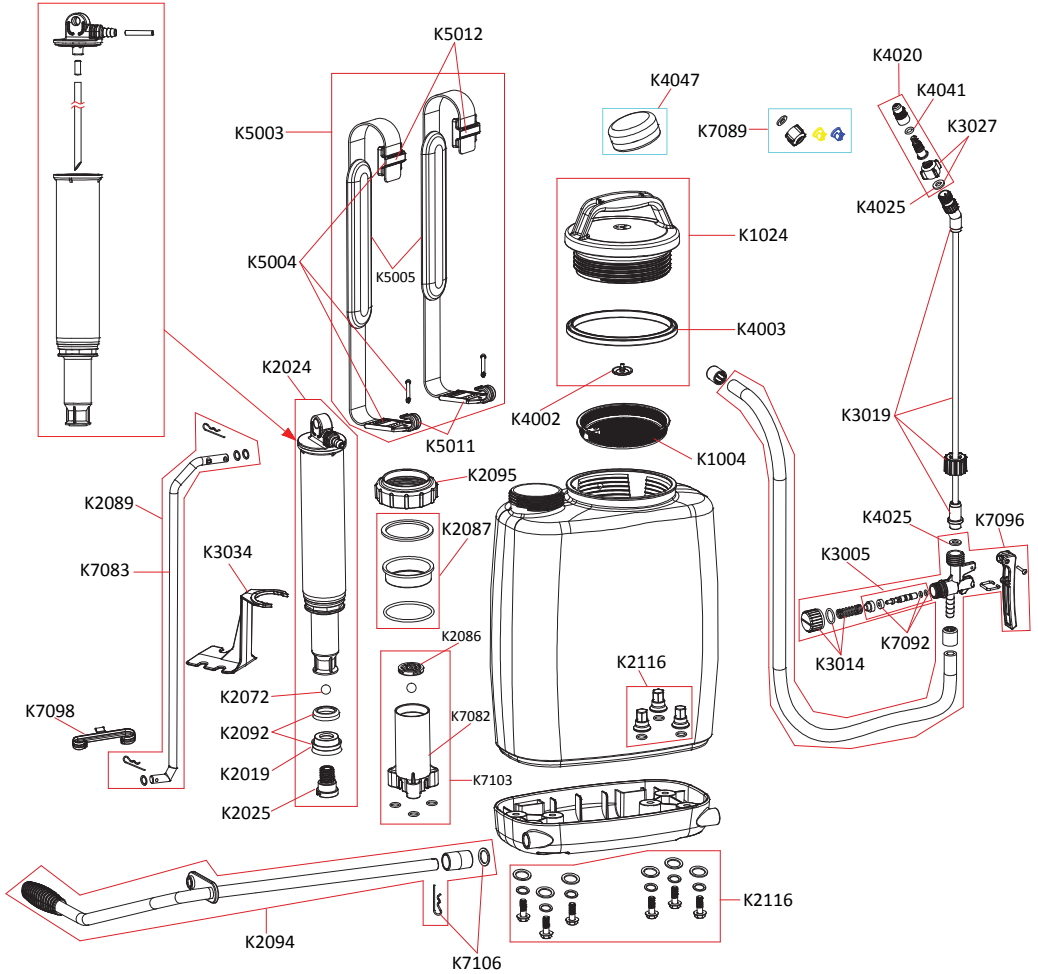



## PART LIST

K1004 STRAINER  
K1024 GREEN LID & SEAL W/ HANDLE  
K2019 PUMP PLUNGER  
K2024 PISTON PUMP ASSEMBLY - 403  
K2025 PISTON HOLDER SCREW  
K2072 STAINLESS STEEL BALL  
K2086 PLASTIC GRATE FOR CYLINDER  
K2087 BUSHING FOR 401/402/403  
K2089 METAL PUMP LEVER WITH LOCKING PIN -403  
K2092 TWO-LIPPED PISTON & PISTON SEAT - 403  
K2094 METAL PUMP HANDLE WITH PLASTIC GRIP  
K2095 THREADED HOLDER FOR PUMP - 403  
K2116 SCREW SET FOR BASE -403  
K3005 PLASTIC SPINDLE SET(NYTREL)  
K3014 PLUG SET  
K3019 FIBERGLASS WAND - 20"  
K3027 NOZZLE HOLDER  
K3034 AGITATOR - 402/403  
K4002 CHECK VALVE  
K4003 SEAL FOR LID - 6"  
K4020 ADJUSTABLE PLASTIC NOZZLE WITH O-RINGS  
K4025 WASHERS SET FOR SPRAY GUN  
K4041 O-RING FOR ADJUSTABLE NOZZLE  
K4047 SILICONE GREASE  
K5003 SHOULDER STRAPS COMPLETE (1 SET)  
K5004 BUCKLE & HOOK FOR SHOULDER STRAP  
K5005 SHOULDER PADS FOR ECOSCAPE SPRAYER  
K5011 BUCKLES FOR SHOULDER STRAPS  
K5012 HOOKS FOR SHOULDER STRAPS  
K7082 CYLINDER BASE - 403  
K7083 METAL PUMP LEVER - 403  
K7089 PLASTIC SPRAY TIP SET  
K7092 SPINDLE SEAL  
K7096 SPRAY GUN B PARTS  
K7098 LEVER HOLDER -- 403  
K7103 PUMP CYLINDER SET  
K7106 R PIN & WASHER

## 8. Important Return Safety Instructions

If it is necessary to return the sprayer for repair, always perform the following tasks before returning the sprayer:

1. In an approved containment area, flush chemical residue from the pump, tank and hoses.
2. Circulate fresh water through the tank, pump and hoses.
3. Indicate the type of chemicals that have been in the sprayer with a label or tag.
4. Include complete description of operation problem, such as how sprayer was used, symptoms of malfunction, how many working hours per day, etc.

Since the sprayer can contain residues of toxic chemicals, these steps are necessary to protect the people who handle return shipments, and to help identify issues and solutions.

## 9. Statement of Limited Warranty

Sprayers Plus shall warrant the equipment described in this manual and shall repair or replace parts and components which, under normal operation and wear, in accordance with technical recommendations, show DEFECTS IN MATERIAL OR WORKMANSHIP, based on the following conditions.

### 9.1 Warranty period

1 (one) year from the date of sale to the original purchaser.

### 9.2 Warranty Registration

Please visit: [www.sprayers-plus.com/warranty](http://www.sprayers-plus.com/warranty)

Sprayers Plus shall honor this warranty, free of charge, if any part or component shows defect in MATERIAL OR WORKMANSHIP, after final analysis at the factory.

### 9.3 This Warranty shall be null & void in case of:

- Misuse of the equipment against specifications in this manual, overwork or accidents.
- Preventive / remedial maintenance performed by unauthorized people or parties.
- Use of parts and components not supplied by Sprayers Plus.
- Modification of the equipment or any characteristic of the original design.

### 9.4 This Warranty shall exclude

- Parts which show wear and tear due to use: spray nozzle, filters, seals, rechargeable battery, hydraulic pump, electronic panel, charger and its cables, agitator lever, belt, UNLESS THEY SHOW DEFECTS IN WORKMANSHIP, ASSEMBLY OR MATERIAL.
- Damages resulting from accidents.
- Transportation or freight of the equipment, parts, and components in case such warranty is not approved.
- Transportation and travel time of technician.

## 10. Maintenance & Lubrication

### 10.1 Lubrication

To prolong the life and maintain good performance of the product, follow the lubrication point(s) and lubricates all moveable rubber pieces with silicone grease.

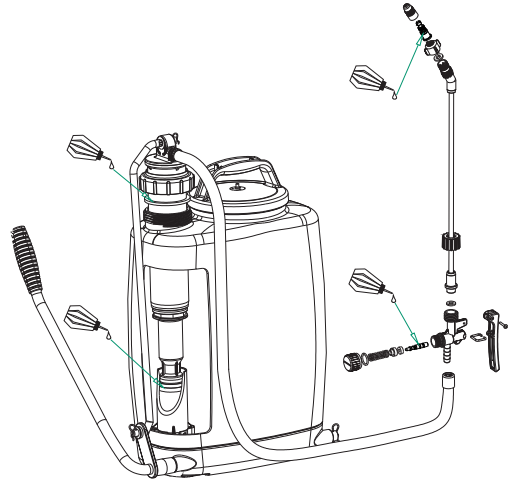

### 10.2 Clean and Wash

Follow the cleaning point(s) and clean your sprayer thoroughly after each use. Soap can be added to the water for better cleaning result.

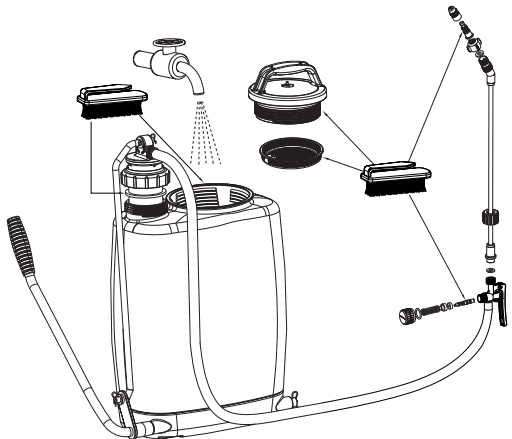

## 11. Troubleshooting

If sprayer is not working as expected, consider the following table before contacting technical assistance.

Fault Status		Cause	Solution
Pump is working, but fluid is not coming out of the sprayer	Trigger valve is not released	Trigger valve is shut	Release trigger valve
	Trigger valve is released	Nozzle or nozzle filter is blocked	Clean or replace nozzle/filter
		Pump suction inside the chemical tank is blocked	Contact for technical assistance
		Suction hose is blocked or disconnected	
	Pump or hoses are leaking		
Pump is not working	Trigger valve is not released	Trigger valve is shut	Release trigger valve
	Trigger valve is released	Nozzle or nozzle filter is blocked	Clean or replace nozzle/filter
		Pump is damaged	Contact for technical assistance
Spray pressure is weak	—	Air accumulation inside the lance	Place the lance with the trigger valve pressed above the base of the sprayer until the spray jet begins to spray continuously
		Pump suction inside the chemical tank is partially blocked	Remove obstruction and circulate clean water to clean the hoses
		Suction hose is partially blocked	Circulate clean water to clean hoses
		Pump or hoses are leaking	Contact for technical assistance
		Nozzle or nozzle filter is blocked or damaged	Clean or replace nozzle/filter
Spraying was normal but stopped suddenly	—	Pump reached maximum pressure and pressure switch activated	Nozzle is plugged. Rinse with clean water
		Nozzle is loosen	Check the nozzle performance chart to confirm if the water flow is within recommended range. Replace with SP certified products if needed
		Nozzle is worn out	



✉ E-mail: [info@sprayers-plus.com](mailto:info@sprayers-plus.com)  
[www.sprayers-plus.com](http://www.sprayers-plus.com)